

TORR

INDUSTRIES

110 3A

SEMI-MANUAL BAG FILLER

The TORR 130 3-A filler, designed and certified to 3-A Sanitary Standards, is an economical solution for accurate filling of bags and pouches from 0.75 to 20 liter capacity.

The 110 is a single head, semi-manual filler requiring each bag to be loaded manually.

Once a bag is loaded into the grip, the operator then removes the cap and inserts the fill valve into the fill gland using the lever arm.

The bag is then filled by simply pushing the fill button once per cycle, delivering the product accurately and consistently every time.

The lever arm is then used to remove the fill valve and re-cap the bag. The bag can now be manually released from the grip.

Each cycle takes 15 - 30 seconds.



See it in action at

www.torrindustries.com/110

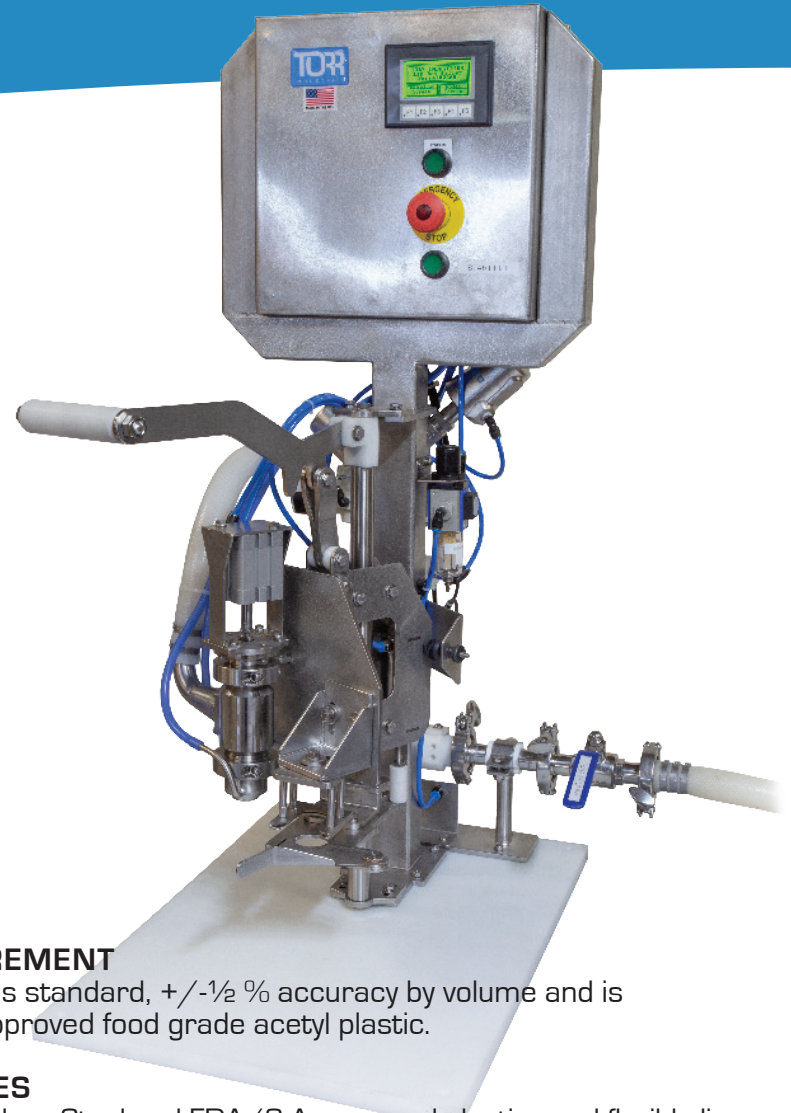

PRODUCT MEASUREMENT

1" turbine flow meter is standard, $\pm 1/2$ % accuracy by volume and is constructed of FDA approved food grade acetyl plastic.

CONTACT SURFACES

All piping is 316L Stainless Steel and FDA/3-A approved plastics and flexible lines.

UTILITIES

110 or 240 VAC 50-60Hz @ 3 amps. Air -90 PSI @ 2 CFM clean, dry air. Vacuum is an option but not included.

PERFORMANCE

Bags per minute is dependent on bag capacity and operator agility. Typically 2 to 4 BPM.

OPERATOR INTERFACE

On-board touch screen for batch counting, and fill volume adjustment.

For a quote or more info please contact:

Chris Rutter
TORR Industries, Inc
chrisr@torrindustries.com
530.247.6909

Offices in:
Melbourne, Australia
Birmingham, UK
California, USA



110 3A

SEMI-MANUAL BAG FILLER

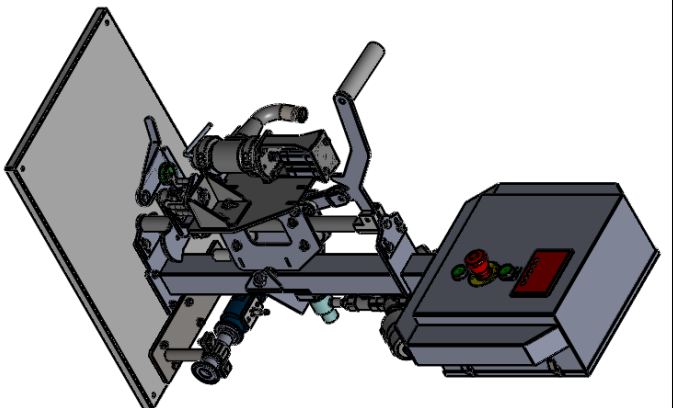
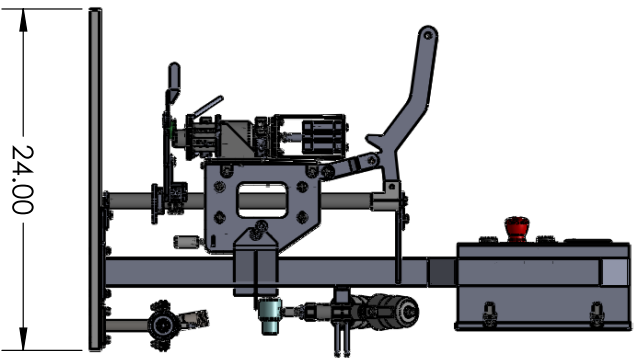
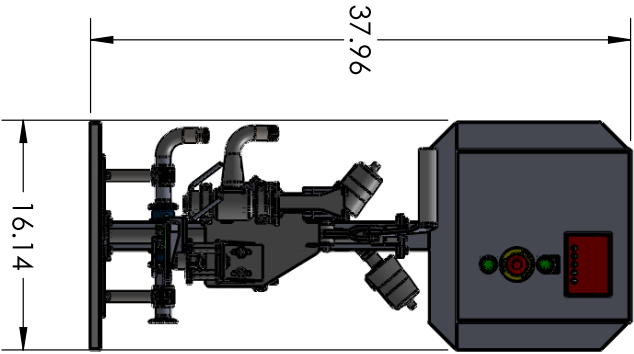
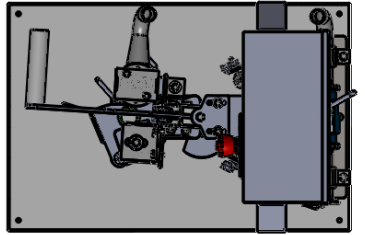

PROPRIETARY AND CONFIDENTIAL.
THE INFORMATION CONTAINED IN THIS DRAWING IS THE SOLE PROPERTY OF TORR INDUSTRIES. ANY REPRODUCTION IN PART OR AS A WHOLE WITHOUT THE WRITTEN PERMISSION OF TORR INDUSTRIES IS PROHIBITED. PROTECTED BY SEVERAL PATENTS PENDING AND ISSUED.

TOLERANCE:
XX ± .01
XXX ± .005
XXXX ± —
ANGLE ± .50 DEG
SURFACE √ 63 RMS

DRAWN	CHECKED	NAME	DATE

UNLESS OTHERWISE SPECIFIED:
DIMENSIONS ARE IN INCHES

MATERIAL:
FINISH:
DO NOT SCALE DRAWING

COMMENTS:

5

4

3

2

1

TORR Industries

TITLE:
TORR 110 FILLER BASE MODEL

SIZE	DWG. NO.	REV
A	512547	

SCALE: 1:1/2 WEIGHT: SHEET 1 OF 1

For a quote or more info please contact:

Chris Rutter
TORR Industries, Inc
chrisr@torrindustries.com
530.247.6909

Offices in:
Melbourne, Australia
Birmingham, UK
California, USA

TORR
INDUSTRIES